

FLOOR HATCH(Steel) + FLOOR STORAGE UNIT

HDIK (Silver) Air tight model for floor tile

Durability • Loading capacity: Pedestrian walk

Japanese conventional construction

18mm tile

Available with special size

Air tight floor hatch with bottom steel board for tile floor

- Feature 1. Suitable for total 18mm thick tile floor 2. High air-tightness model with airtight material on back of inner hatch
3. High durability for floor tile use

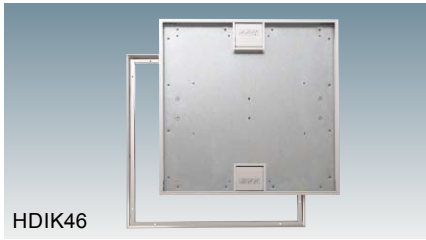

HDIK46



HDIK60

Silver



HDIK

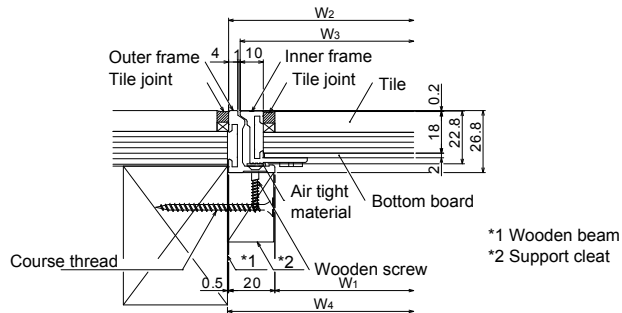
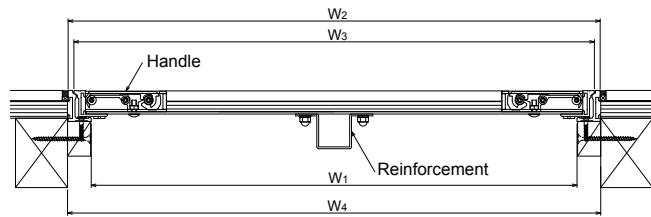

*1 Wooden beam
*2 Support cleat

Standard size / Option parts

Name	Standard size (mm)				*3	Option parts	
	W1	W2	W3	W4		Wooden screw (Ø3.1 x 20)	Tapping screw (Ø4 x 10)
HDIK46	420	460	450	461	1	8	14
HDIK62	546.6	609	298.5x598	609	4	8	22

- Special size is available within W2 = 300 x 300 or more, 606 x 1203 or less.
- Use for total 18mm thickness floor tile. • high durability for floor tile use.
- For thick adjustment, use plywood between bottom board and tile.
- Available key-cylinder. • HDIK 60 is not air tight model of JIS A-4 level due to dividing into 2 hatch.

46 size passed A-4 level of JIS A4706. (Gap square: 1.0 (cm²/m²) or less.
HDIK60 can be installed floor storage unit.

Parts

Parts	Material	Finish	Note
Inner/Outer frame	A6063S-T5	Anodic oxidation composite coating	
Bottom board	SGHC-Z27		t2.0
Handle	A6063S-T5	Anodic oxidation composite coating	
Handle frame	A6063S-T5	Anodic oxidation composite coating	
Air tight material	Forming resin		
Hatch reinforcement	SGHC-Z27		t1.6
Fixing screw	Steel	Electro galvanizing	

PKT60-OP2 Option model for floor hatch HDIK/HFT



HDIK-60

PKT60

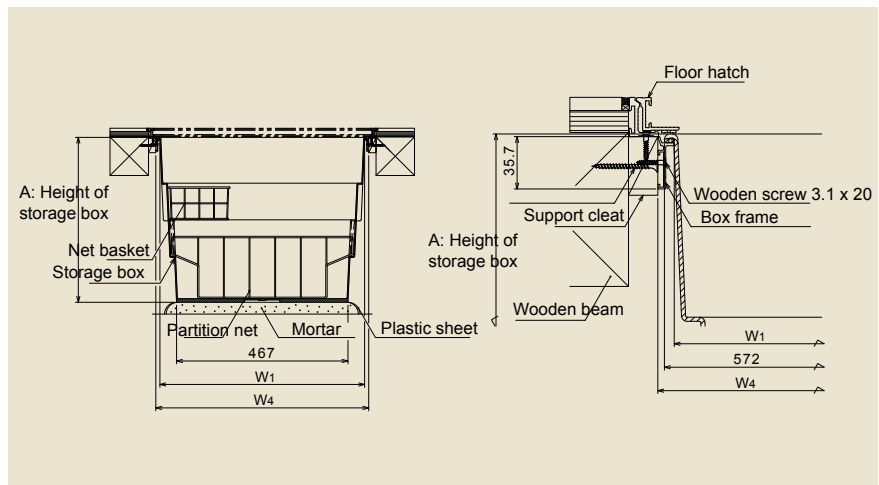

Standard size

Name	Color	Standard (mm)			Capacity (L)	Type
		W1	W4	A		
PKT60-WOP2	Silver	558.6x558.6	581x581	450	110	-
PKT60U-WOP2				300	80	Shallow

- Storage unit (box + frame) for HDIK/HFT
- HDIK/HFT is sold separately.
- Ask hatch size when other model than HDIK60/HFT60B is installed.
- HDIK60 is heavy hatch.
(Tile finish becomes heavier. Need to handle with care.)
- Width of support cleat to be 20mm.

Silver



PKT-WOP2

Parts

Parts	Material	Finish	Note
Box frame	A6063S-T5	Anodic oxidation composite coating	
Storage box	Polypropylene		
Net basket	SWRM	Resin coating	Deep type only
Partition net	SWRM	Resin coating	Deep type only
Box hanger	SPCC	Electro galvanizing	Deep type only

Option

	(Pcs)	
	PKT60-WOP1	PKT60U-WOP2
Flat wood screw (Ø3.1x20)	8	8
Storage box	1	1
Net basket	1	-
Partition net	1	-
Box hanger	-	1