

SLIDEX HCH-80NB

HORIZONTAL RAIL TYPE

– INSTALLATION PROCEDURE –

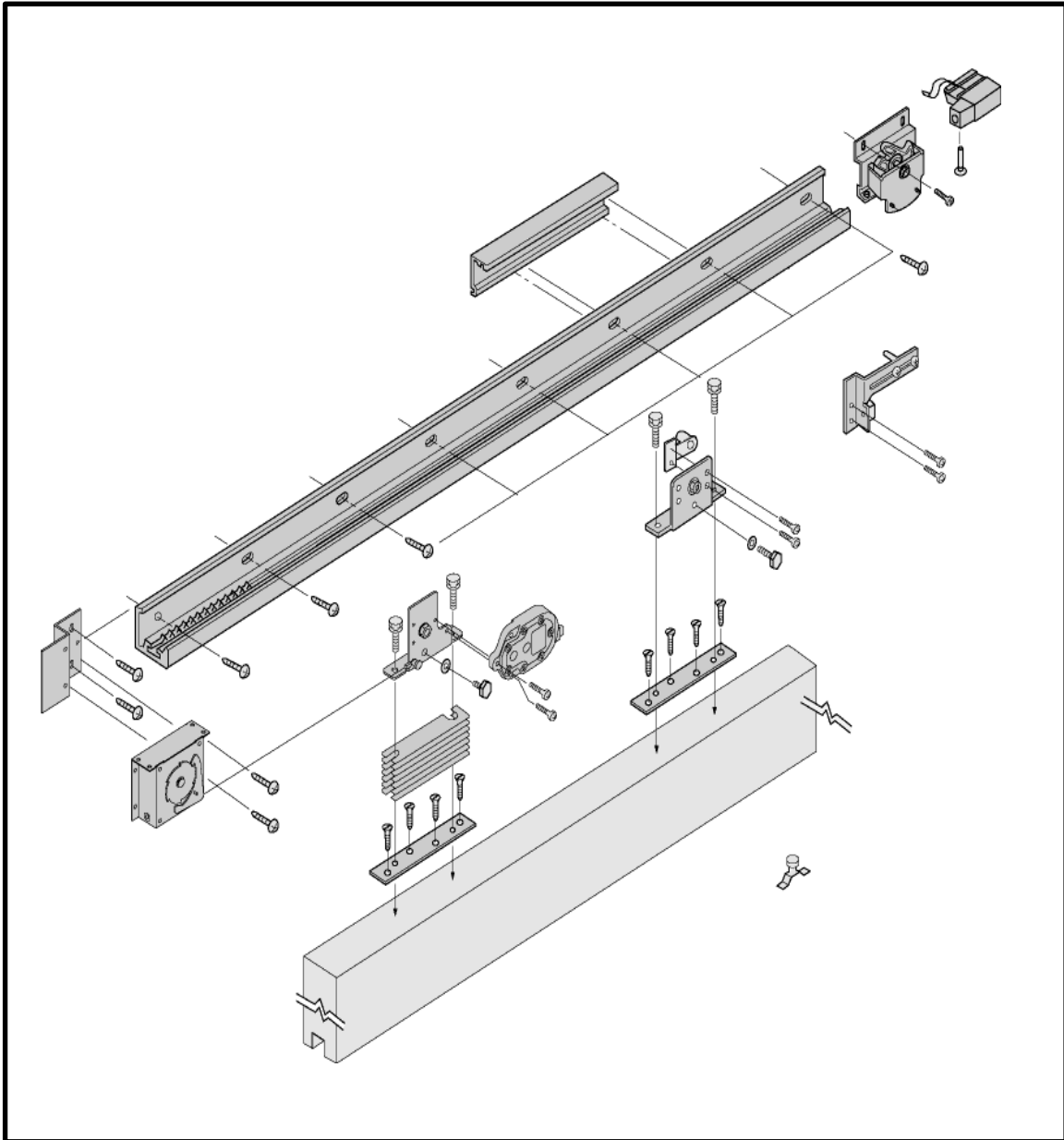

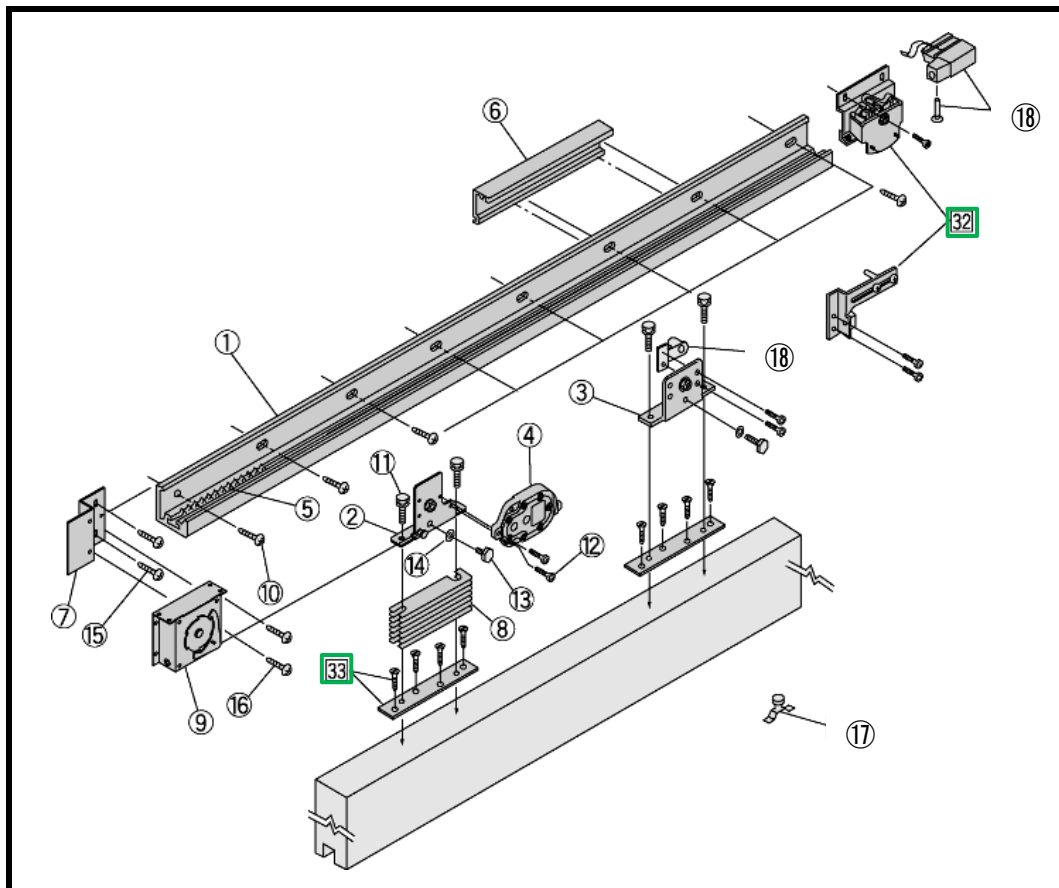

<BASIC PARTS>

	Name	Material	Number
①	Aluminum rail 2,200mm	Aluminum material	1
②	Front hanger roller	Steel(chromate, resin)	1
③	Rear hanger roller	Steel(chromate, resin)	1
④	Hydraulic control	ADC12 and others	1
⑤	Braking rack	Resin(with G), Urethane	1
⑥	Rear side brake rack	Aluminum materials, Resin, Urethane	1
⑦	Mounting Bracket	Steel(chromate)	1
⑧	Height adjustment plate	Steel(processed steel plate)	7 (1)
⑨	Power spring	Steel(chromate)	1
⑩	M5 x 16 pan head screw	Steel(chromate)	10 [12]
⑪	M8 x 35 hexagon nut	Steel(chromate)	4
⑫	M5 x 16 pan head screw	Steel(chromate)	2
⑬	Latch hexagon special bolt	Stainless	2
⑭	Nominal 10-dia. Countersunk spring washer	Stainless	2
⑮	M5 x 12 pan head screw	Stainless	2
⑯	M4 x 6 pan head screw	Stainless	2
⑰	Guide roller	Roller-Urathane,Plate stainless	1
⑱	Stopper Door stop	Aluminum, rubber	1
	Stopper Roller	Resin	1
	M6 x 20 hexagon bolt	Steel(chromate)	1
	M5 x 12 pan head screw	Steel(chromate)	2

<OPTIONAL PARTS>

	Name	Number
32	Delayed timer body	1
	Time adjusting plate	1
33	Wooden door plate	2
	Nominal dia. 5 x 30 countersunk tapping	8

This guide is for right hand opening of the door.
Left hand opening is simply a mirror image.

1. RAIL

① Install optional parts

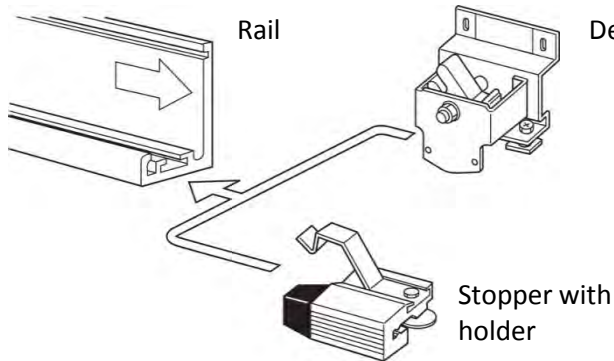

Insert either Stopper with holder or Delayed timer.

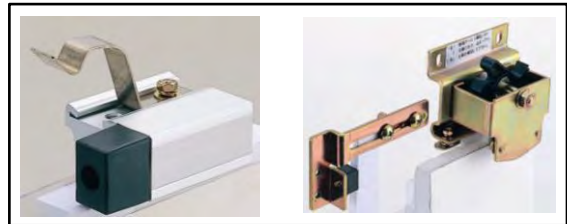

② Cut rail (Cutting stamp side)

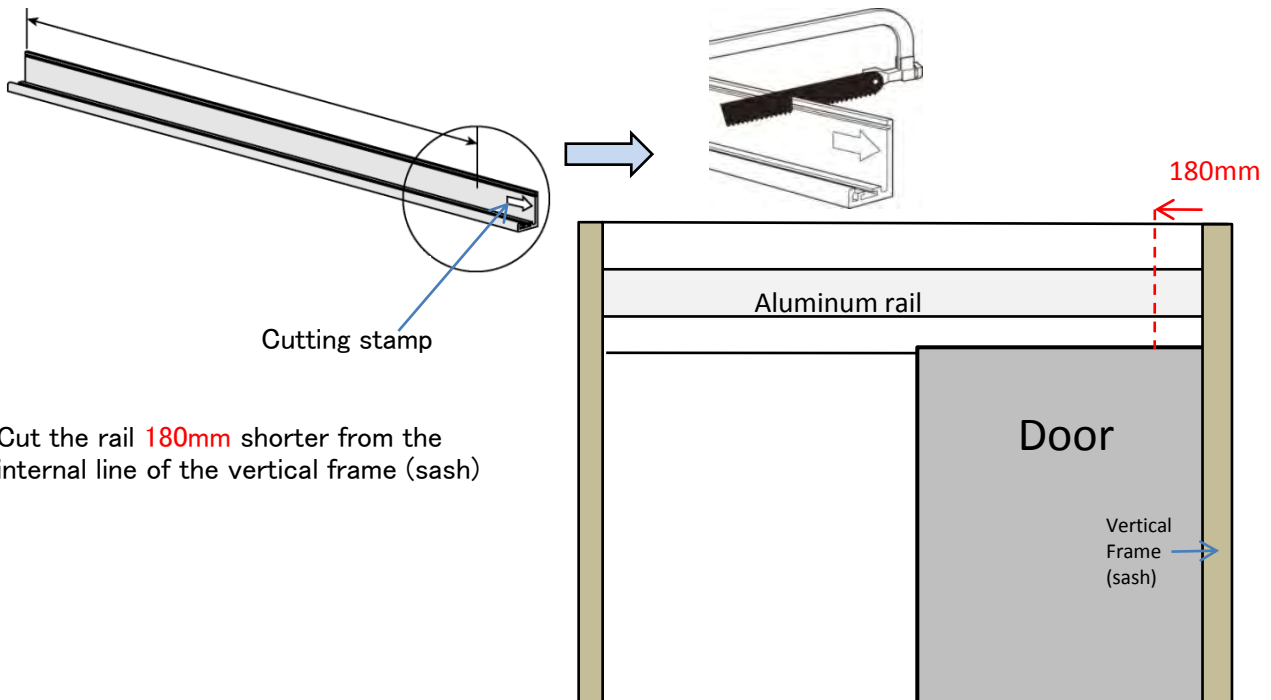

Cut the rail **180mm** shorter from the internal line of the vertical frame (sash)

③ Set up the rear side screw hole

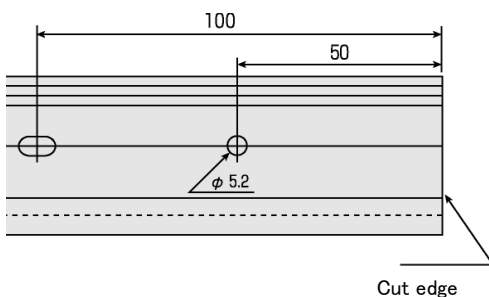

After cutting the rail, if the predrilled screw hole location becomes more than 100mm from cut edge, drill a 5.2mm ϕ hole with the distance of 50mm from edge.

④ Hole location on wall

1. Decide hole location.

$$\text{Hole position} = \text{DH} + 7\text{mm} + \text{B}$$

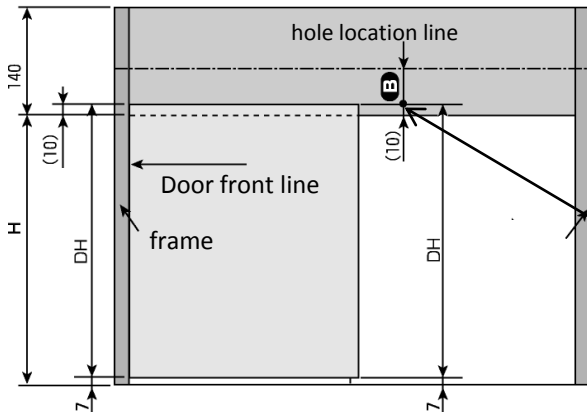

Article Number	B	Steel plate for Wooden door Optional parts.**
HCH-80/8015NB	62mm	68mm

** In case of wooden door, B changes to 68mm because it is added steel plate such as P.6 drawing.

This is overlapped portion with door top and base frame.



2. Drill and tap holes at intervals of each 300mm.

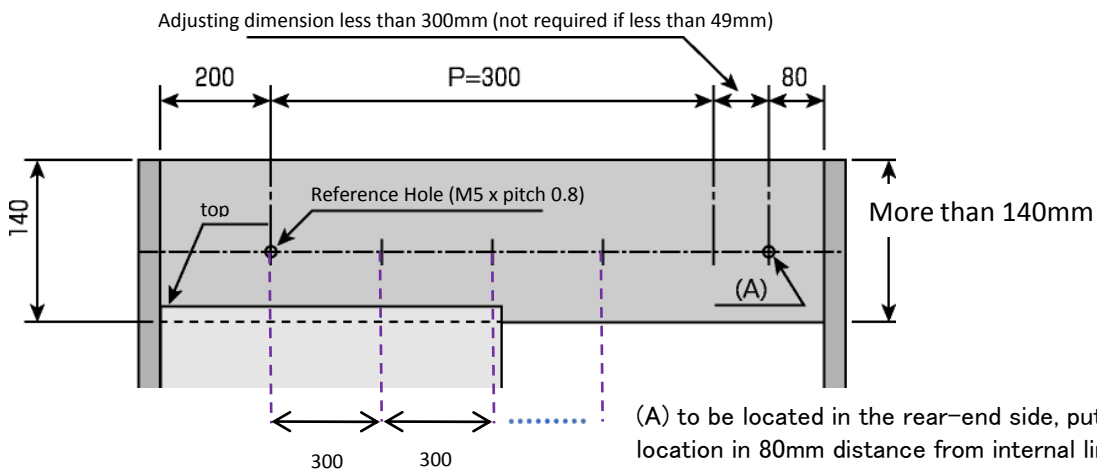

(A) to be located in the rear-end side, put it at the location in 80mm distance from internal line of frame. However the dimension is less than 49mm, this fabrication is not required.

⑤ Fix the rail

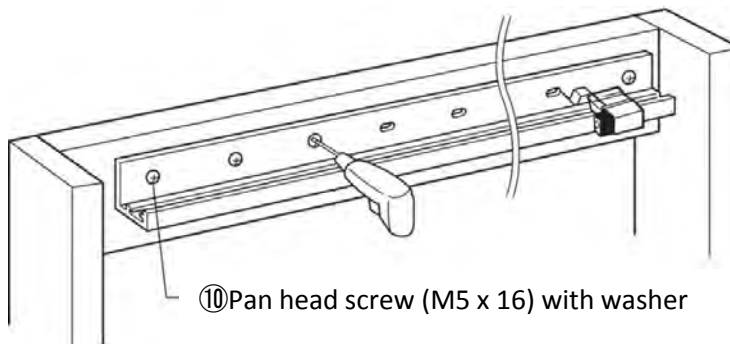

⑩ Pan head screw (M5 x 16) with washer



1. Install the rail horizontally.
2. Pay special attention on the rail-surface where rollers run so that surface may not receive any damage.

2. POWER SPRING UNIT

① Install of Mounting Bracket for Power Spring

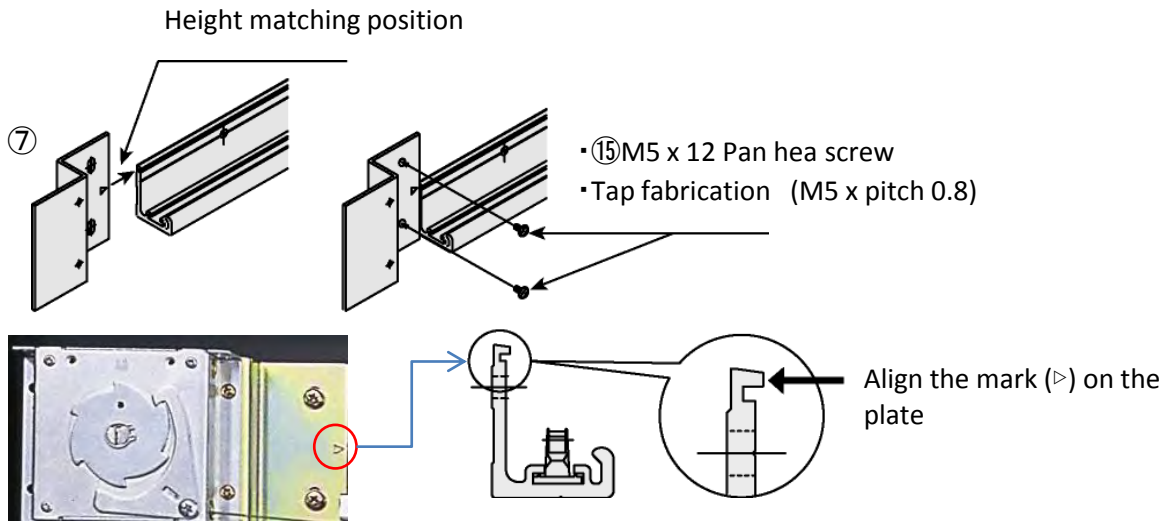

Fix the mounting bracket with no clearance in between bracket & front edge of aluminium rail.

② Mounting the body of Power Spring on the bracket

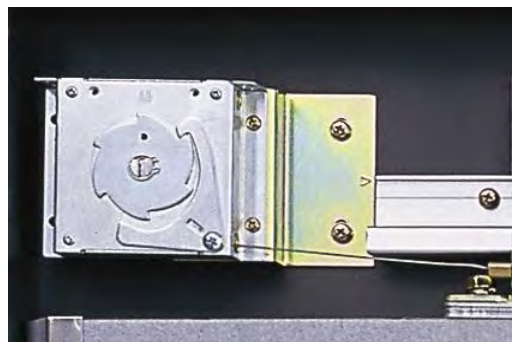
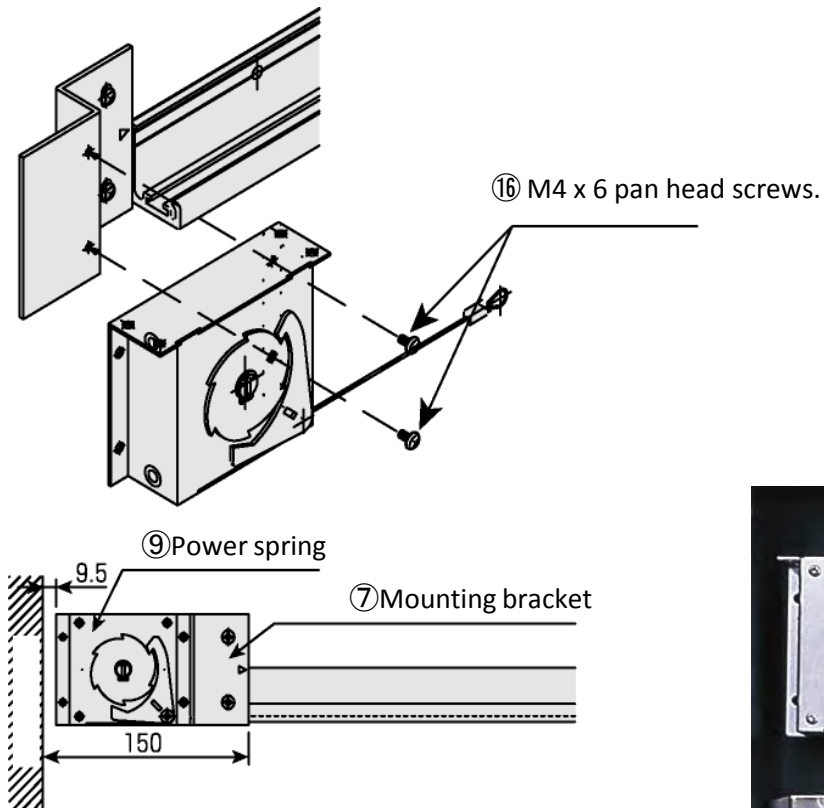

3. HANGER ROLLERS

① Installation of Hanger rollers

1. Fix the Front Hanger roller and put 7 pcs. of height adjustment plates under front hanger roller.
2. Fix it by hex. Bolts (M8 x 35).

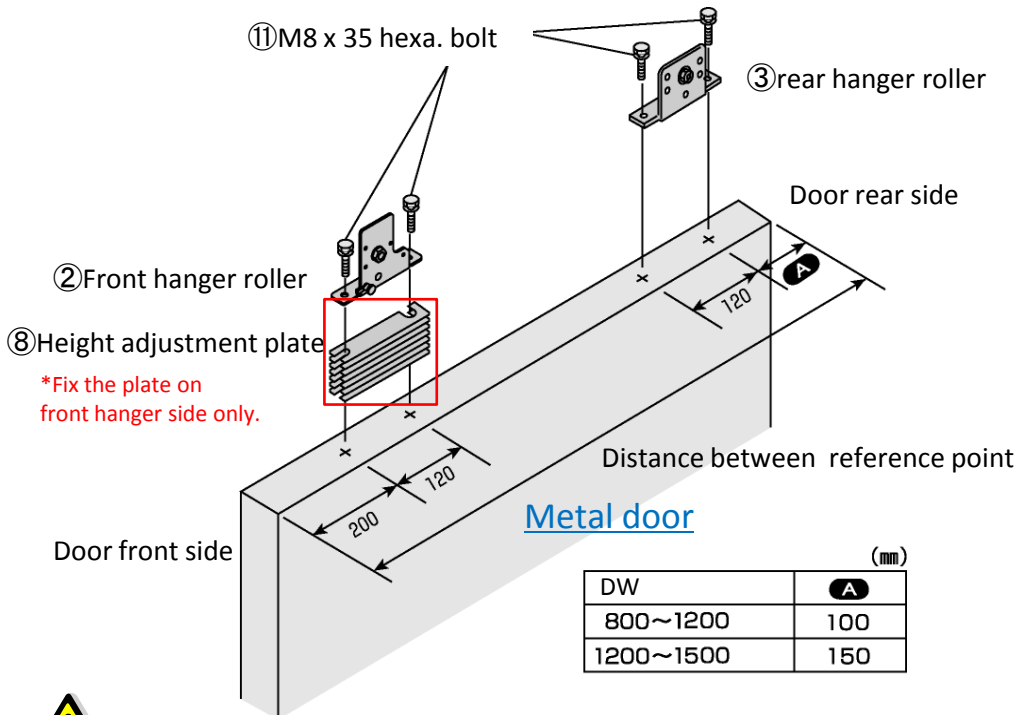

Ensure the hangers are fixed squarely and in line with the door.

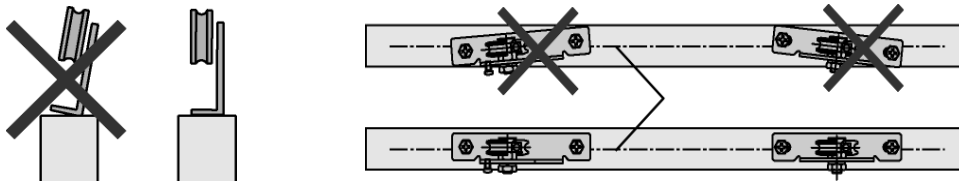

OPTION: For Woden door installation

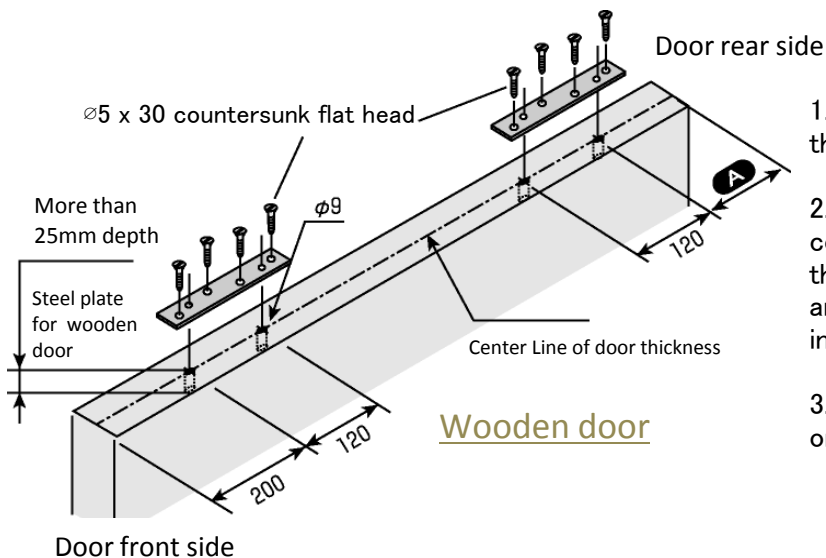

1. Drill the four 9mm dia holes into the top of the door .

2. Fix the door plate with the countersunk flat head screws making sure the 9mm holes drilled in the top of door are aligned with the clearance holes in the plate.

3. Proceed the fixing job of nomal door on it.

② Installation of the guide roller

***If not fixing guide roller, door would be unstable.**

Install the guide roller at the center of overlapped portion.

*Standard set including 16 mm guide roller.

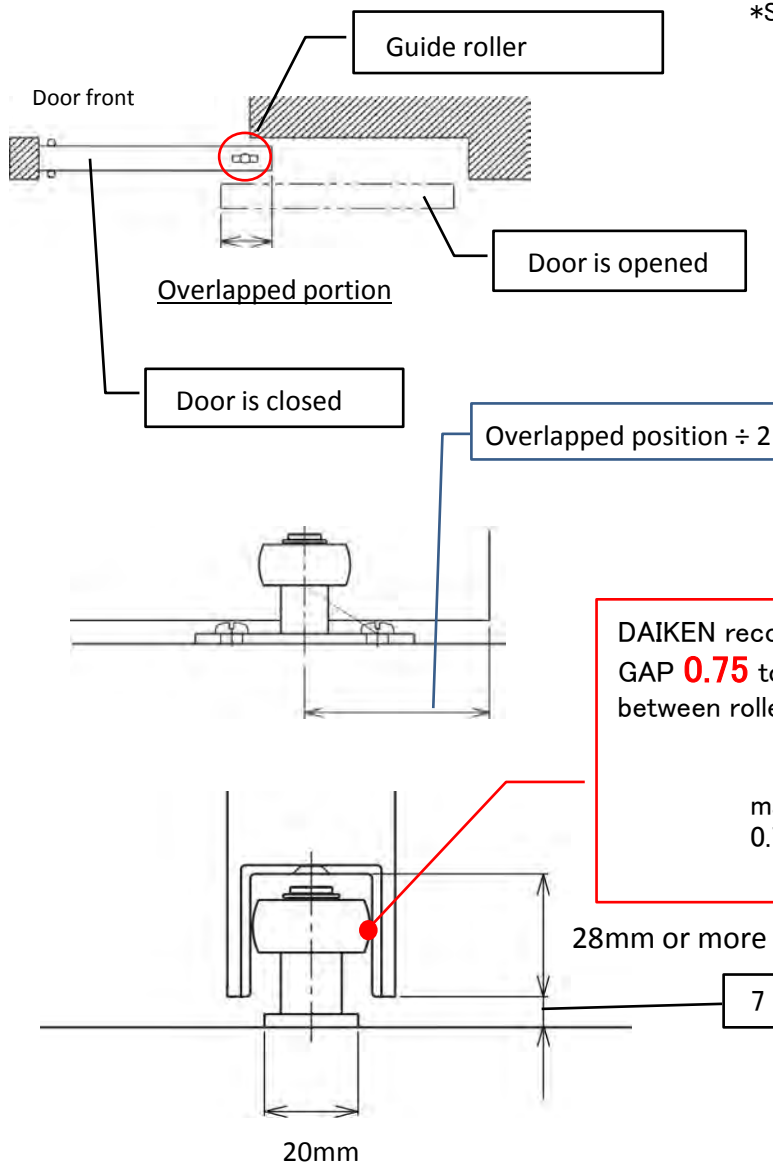

16mm type



25mm type



30mm type



DAIKEN recommendable best position of GAP **0.75 to 1.00** mm between roller and wall.

make the GAP 0.75 to 1.00 mm

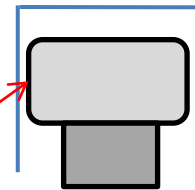

③ Installation of guide rail (option parts)

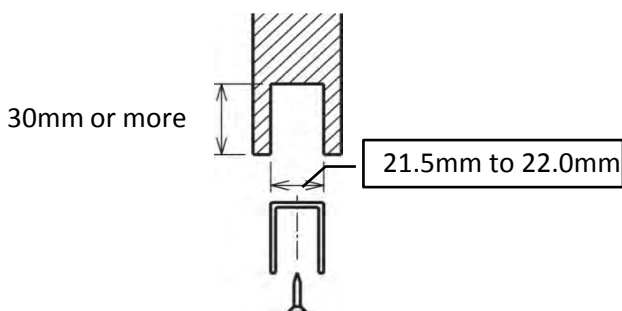

1. Cut the guide rail by aligning it with the wooden door width.
2. Cut in the bottom portion of the wooden door, and install the guide rail with the attached screw.

⚠ Guide rollers other than 16 diameter cannot be used.

5. DOOR HANGING

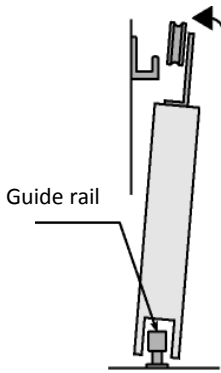

1. Fit the guide roller with the bottom portion of the door.
2. Hang the sash rollers on the rails.
3. Check that the door can slide smoothly and that there are no clearance problems.



1. Take care so that the rail running face is not scratched when hanging the door.
2. Never start hanging door with Hydraulic control on front hanger roller.
3. Be careful with your fingers. At this point, the brake does not yet work. Careless work will result in pinching your fingers.

Fit the door latching bolt. (**fastener bolt**)

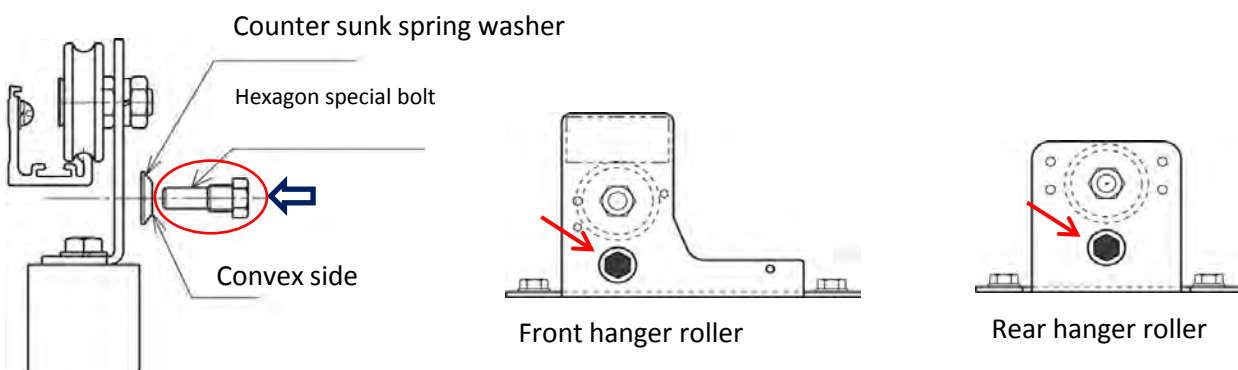

Insert the countersunk spring washer into hexagon special bolt for both the front and rear hanger rollers and tighten it.

Note: Face the convex side of the countersunk spring washer toward the head of the hexagon special bolt.



Don't forget to fit fastener bolt because it prevents from dropping door out from rail.

6. STOPPER

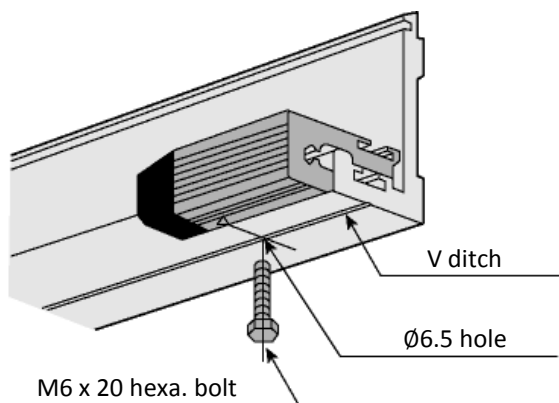

Loosen screw which tightened in 1-③.
Adjust stopper position for doors to be zero gap when they are closed.

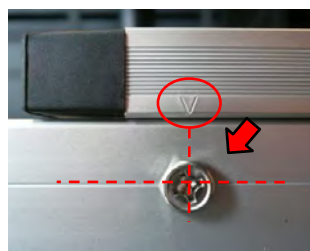

Put $\varnothing 6.5$ hole on cross point of delta mark and V ditch.

Fix stopper with M6 x 20 bolt.

7. INSTALLATION OF THE REAR SIDE BRAKE (Back check)

1. The door to be fully opened.
2. Insert the rear side brake into the groove

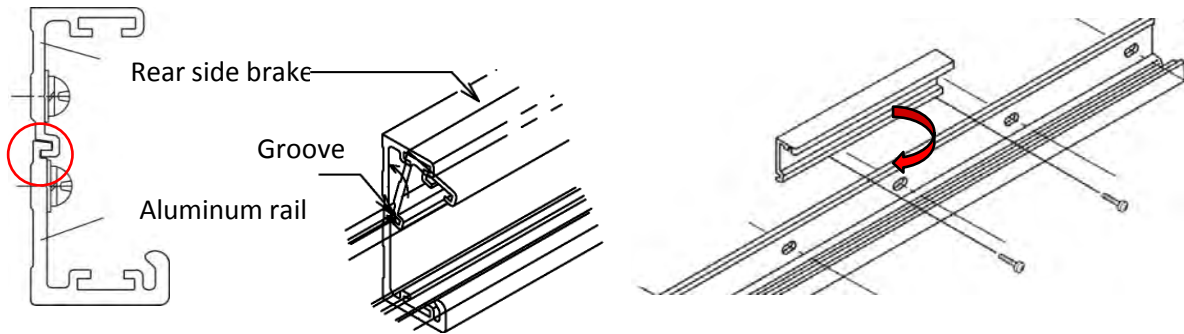

3. Align the front side of the front hanger roller with the stamping position of the rear side brake center as shown in the drawing.

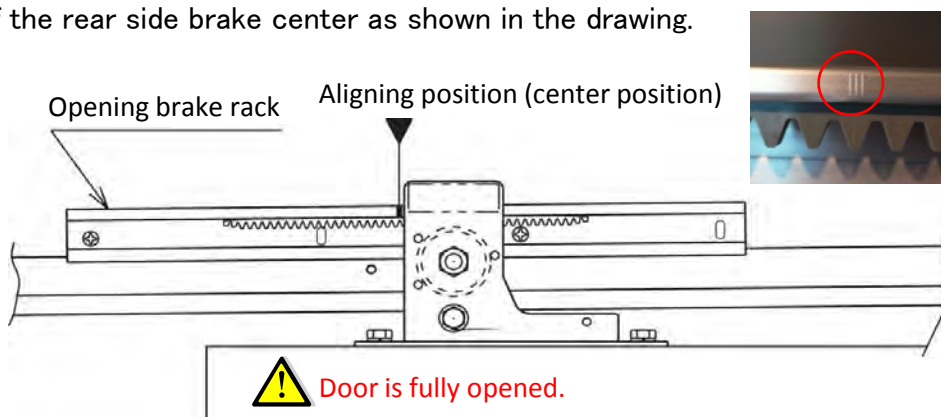

4. Tap machining (M5 pitch 0.8) and Tighten by the pan head screw (M5 x 16)



Right hand

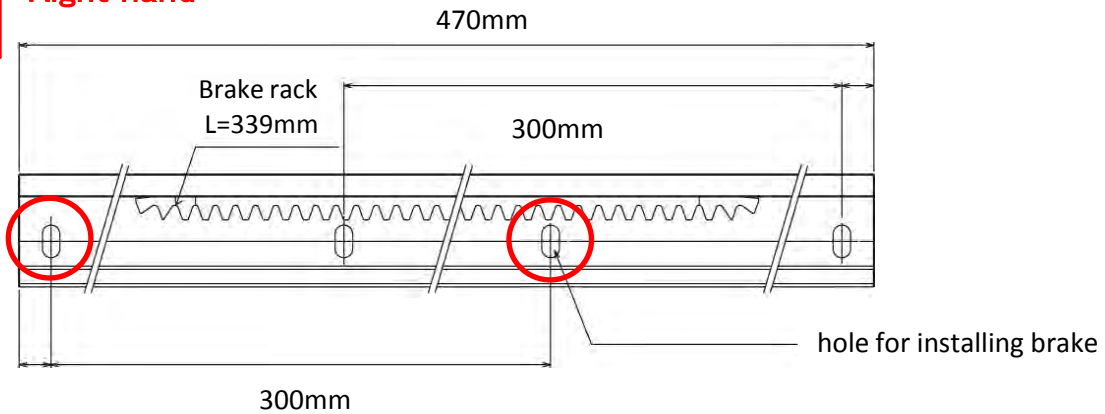

Left hand

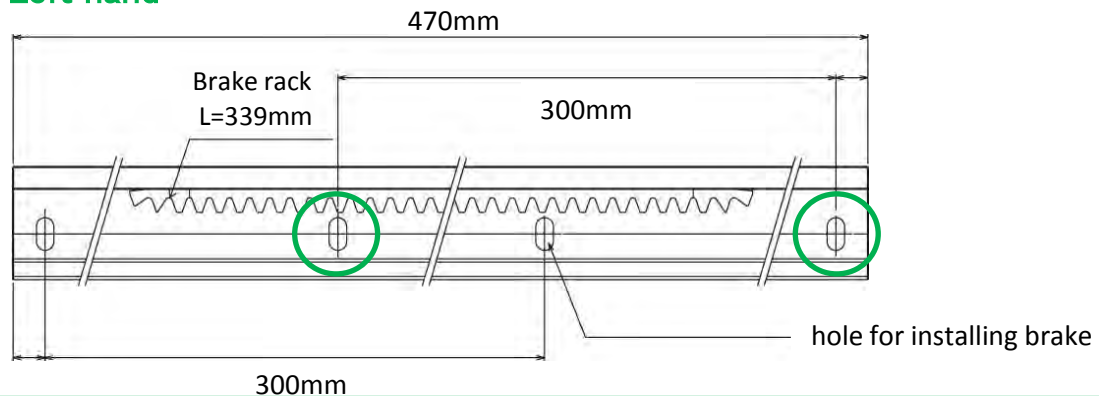

8. INSTALLATION OF THE HYDRAULIC CONTROL

① Installation

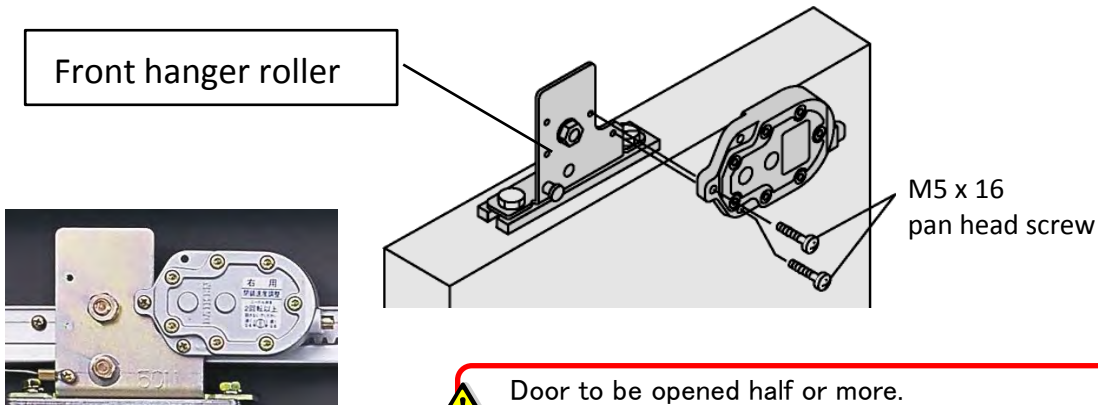

② Fix the wire on the front hanger roller

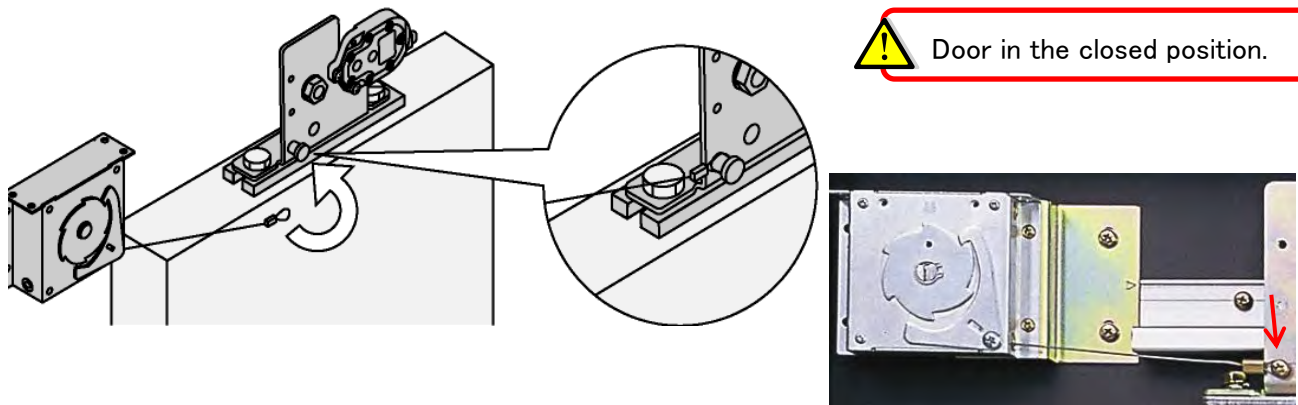

Pull the control wire from the Power Spring and hook the wire loop on to the front hanger.

9. HOW TO CONTROL POWER SPRING

① Adjusting the closing power and speeds

To make pulling power stronger

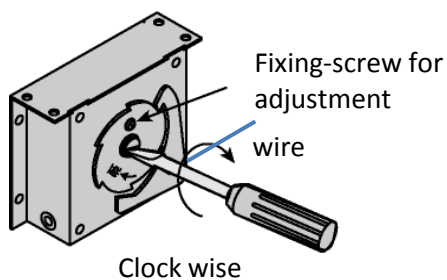

1. Temporarily remove the fixing-screw for adjustment.
2. Rotate to clockwise direction and adjust properly.

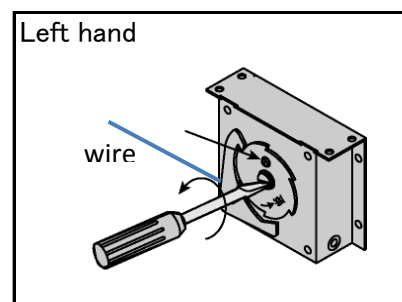

To make pulling power weaker

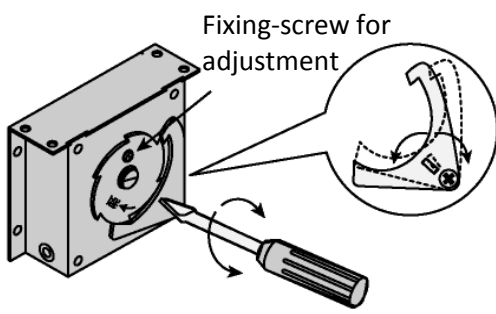

1. Remove the fixing-screw for adjustment.
2. Rotate to anti-clockwise direction and adjust properly.

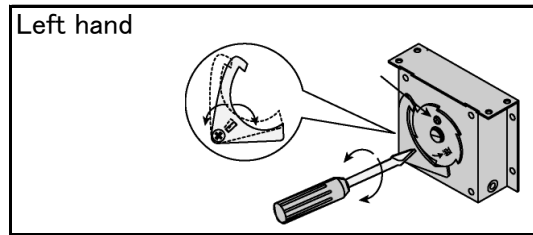

- ⚠ 1. After pulling power was adjusted, put back the fixing screw for adjustment to original position.
- 2. Check the closing performance after every 1 full rotation.

② Adjustment of door closing speeds

*Adjustment can be controlled about 250mm short from door closed position.

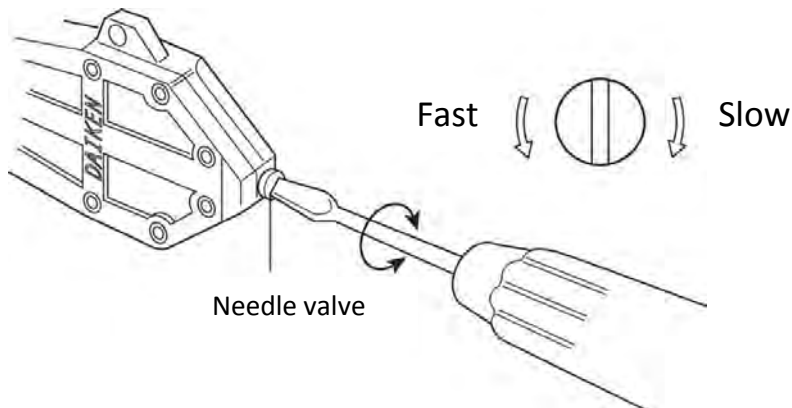

- ⚠ Do not turn the needle valve more than 2 times.

– COMPLETED –

